

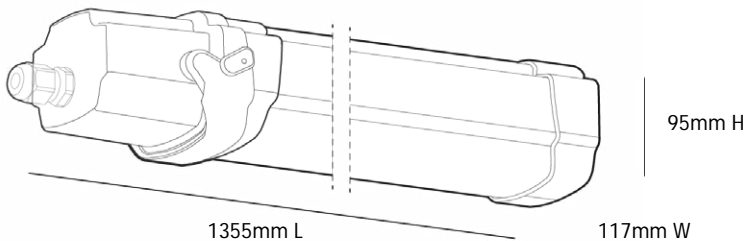

# STORM X

SURFACE MOUNTED LUMINAIRE  
IP69, IK10





### Description

The Storm X is an IP69 and IK10 rated surface mounted luminaire. Storm X is suitable for Car parks, Factories, Warehouses, Cool Rooms and any place that a fully sealed, high impact luminaire is required. The frosted polycarbonate diffuser spreads the light further across the ceiling to provide a larger distribution of light while maintaining great uniformity. Fitted with high quality LED modules using the latest in lighting technology to guarantee the end user receives outstanding illumination. Designed to be surface mounted to fit any non corrosive environment.

### Features

- LED Outputs and LED Lamp Colour options available
- IP69, IK10
- Luminaire lifetime L80/B10 >72,000hours
- MacAdams 3 SDCM
- Ta: - 30°C to +45°C
- Injected Polycarbonate with UV protection.
- Upper part dark grey RAL 7046

### Options

- Ultra Dim (Extra Low Dimming to 0.1%)
- Dim (Dali Dimming to 1%)
- 90+CRI
- Casambi

### Installation

- Suitable for outdoor areas which are non corrosive and covered by roofs.
- Not recommended for open rooftops as prolonged exposure to direct UV rays may cause deterioration of housing & gaskets.

### Photometrics

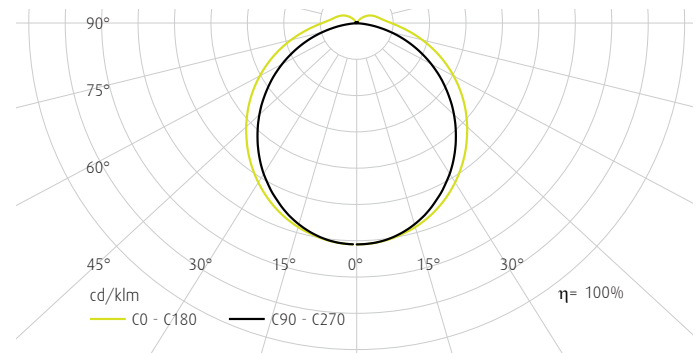

CODE	ABSOLUTE LUMENS	DIMENSIONS (L X W X H)
STM X - SM - 1200 - 23w - (2.7 or 3 or 4K)	3233Lm	1355 x 117 x 95mm
STM X - SM - 1200 - 36w - (2.7 or 3 or 4K)	4909Lm	1355 x 117 x 95mm
STM X - C - SM - 1200 - 23w - (2.7 or 3 or 4K)	3233Lm	1261 x 117 x 95mm
STM X - C - SM - 1200 - 36w - (2.7 or 3 or 4K)	4909Lm	1261 x 117 x 95mm

### LED PRODUCT LEGEND

STMX	-	C	-	SM	-	1200	-	23W	-	4K
RANGE		CONTINUOUS *IF APPLICABLE		MOUNTING		LENGTH		SYSTEM WATTS		LED COLOUR





lime lite

# STORM X

SURFACE MOUNTED LUMINAIRE

The Storm X-Continuous allows for a continuous IP69 and IK10 rated surface-mounted system with its innovative through loom electrical connection and lever mechanism. The continuous Storm X endcap ensures seamless mechanical and electrical connections for a hassle-free setup.

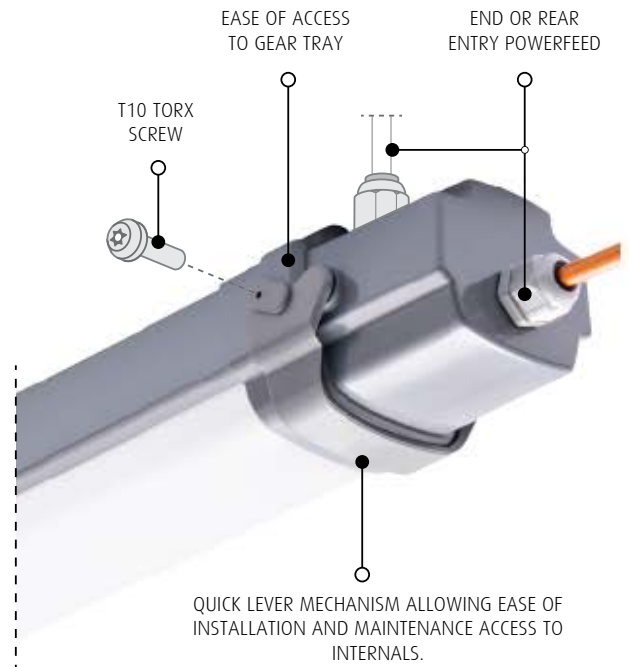
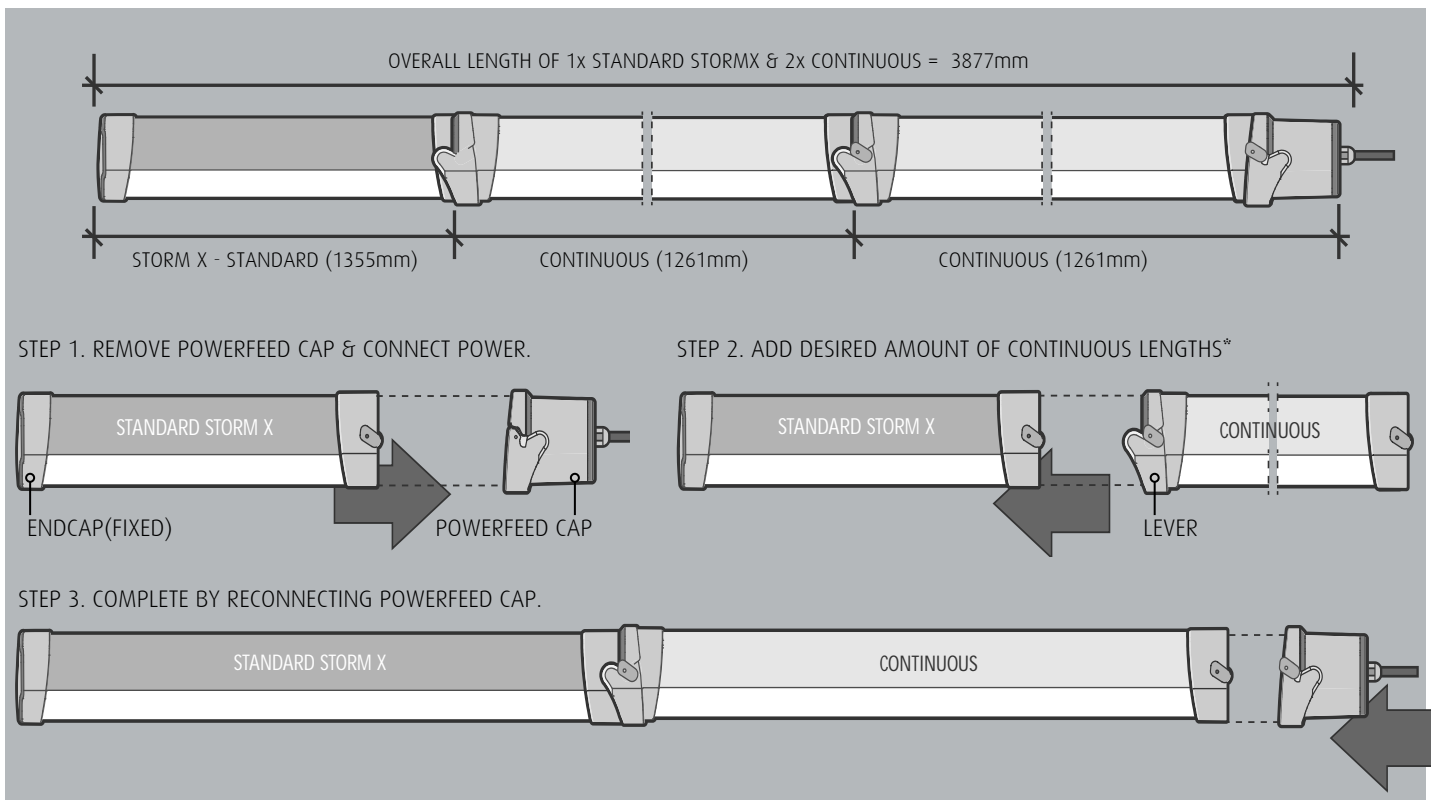

DIAGRAM A. OVERVIEW OF CONTINUOUS STORM X ARRANGEMENT.



**NOTE:**  
REFER TO INSTALLATION GUIDE FOR SPECIFIC INSTALLATION INSTRUCTIONS.  
\*\*MAXIMUM AMOUNT OF CONTINUOUS LENGTHS DEPENDANT ON SITE ALLOWANCE AND ONSITE SPECIFICATION.